



**FITTING INSTRUCTIONS FOR PT0002MC REPLACEMENT PEDAL TIP  
HARLEY-DAVIDSON STREET 750/500 2015- GEAR SHIFT LEVER ONLY**



**THIS KIT CONTAINS THE ITEMS PICTURED AND LABELLED BELOW.  
DO NOT PROCEED UNTIL YOU ARE SURE ALL PARTS ARE PRESENT.**

**Please note that the way the kit is packed does not necessarily represent the way of mounting to the bike**

Please note that in cases where kits are packed with a plastic tube separating components on the spindle bar (this tube should be discarded).

THE PARTS SHOWN MAY BE REPRESENTATIVE ONLY (FOR CLARITY OF INSTRUCTIONS ONLY)

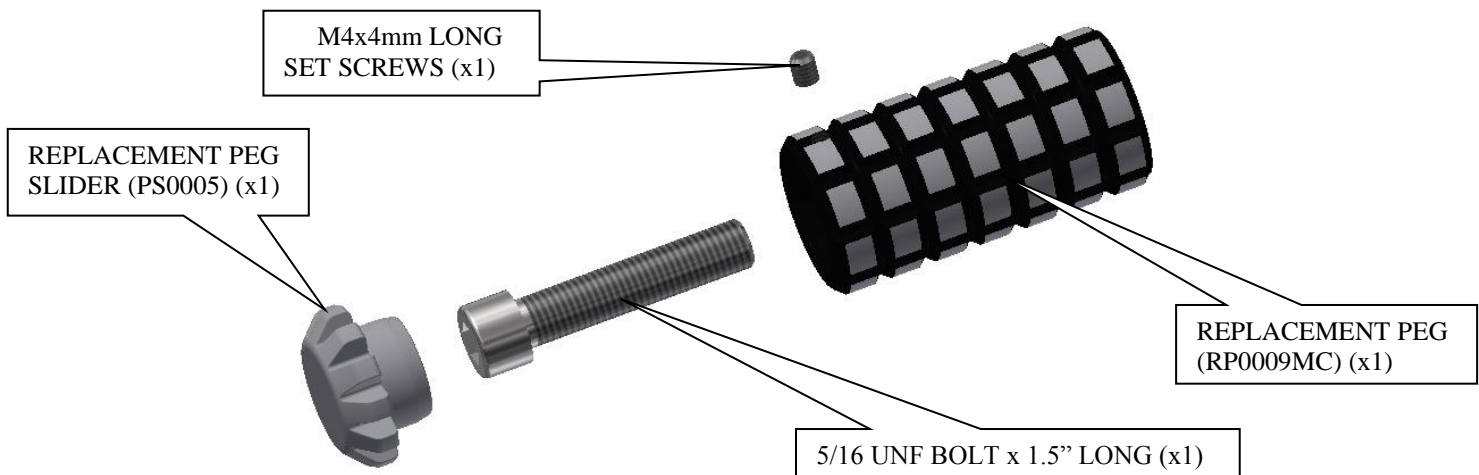

**TOOLS REQUIRED**

- 1/4" A/F Allen Key.
- 1/2" Spanner or Socket and Wrench.
  - 2mm Allen Key.



## **FITTING INSTRUCTIONS**

- Remove the locking nut on the gear shift lever pedal tip and remove the original pedal tip.
- Place the bolt through the replacement peg so the head of the bolt goes into the counter bore.
- Offer into position and secure using the original locking nut (please ensure the set screw hole is pointing downwards when tightened).
- Fit the peg slider into the counter bore so the logo is level (it also hides the bolt head).
- Fit the set screw into the tapped hole in the new pedal tip and secure the peg slider in position.

ISSUE 1 26/10/2016 (NSY)

## **CONSUMER NOTICE**

The catalogue description and any exhibition of samples are only broad indications of the Products and R&G may make design changes which do not diminish their performance or visual appeal and supplying them in such state shall conform to the order. The Buyer acknowledges no representation or warranty (other than as to title) has been given or will apply to the Products other than those in R&G's order or confirmation and the Buyer confirms it has chosen the Products as being of merchantable quality and suitable for its particular purposes. Where R&G fits the Products or undertakes other services it shall exercise reasonable skill and care and rectify any fault free of charge unless the workmanship has been disturbed. The Buyer is responsible for ensuring that the warranty on the motorcycle is not affected by the fitting of the Products. On return of any defective Products R&G shall at its option either supply a replacement or refund the purchase money but shall not be liable if the Products have been modified or used or maintained otherwise than in accordance with R&G's or manufacturer's instructions and good engineering practice or if the defect arises from accident or neglect. Other than identified above and subject to R&G not limiting its liability for causing death and personal injury, it shall not be liable for indirect or consequential loss and otherwise its liability shall be limited to the amounts paid by the Buyer for the Products or the fitting or service concerned. These terms do not affect the Buyer's statutory rights.

## **R&G RACING RETURNS POLICY (NON-FAULTY GOODS)**

Returns must be pre-authorized (if not pre-authorized the return will be rejected). Goods may only be returned direct to us if they were purchased direct from us (customer must prove if necessary). Otherwise to be returned to original vendor. Goods must be in re-sellable condition, in the opinion of R&G Racing. All returns are subject to a 25% restocking and handling fee (25% of the gross value exc. P&P – at the prevailing price at time of purchase). The customer must pay any and all carriage charges. No returns of discontinued products, unless within 14 days of purchase. This policy does not affect your statutory rights and does not refer to faulty goods.



**NOTICE DE MONTAGE POUR PT0002MC POINTE DE REMPLACEMENT**  
**HARLEY-DAVIDSON STREET 750/500 2015-**  
**COTE LEVIER DE VITESSE UNIQUEMENT**



**LE KIT CONTIENT LES ARTICLES EXPOSES CI-DESSOUS, VERIFIER QUE TOUTES LES PIECES SOIENT PRESENTES AVANT DE PROCEDER AU MONTAGE.**

**La façon dont le kit est emballé ne correspond pas forcément à la façon de monter les pièces sur la moto.**

Notez que si les kits sont emballés avec un tube en plastique qui sépare les composants sur l'axe, ce tube doit être jeté).

LES PARTIES PRESENTEES PEUVENT ETRE UNIQUEMENT REPRESENTATIVES  
(POUR LA CLARTE DES INSTRUCTIONS UNIQUEMENT)

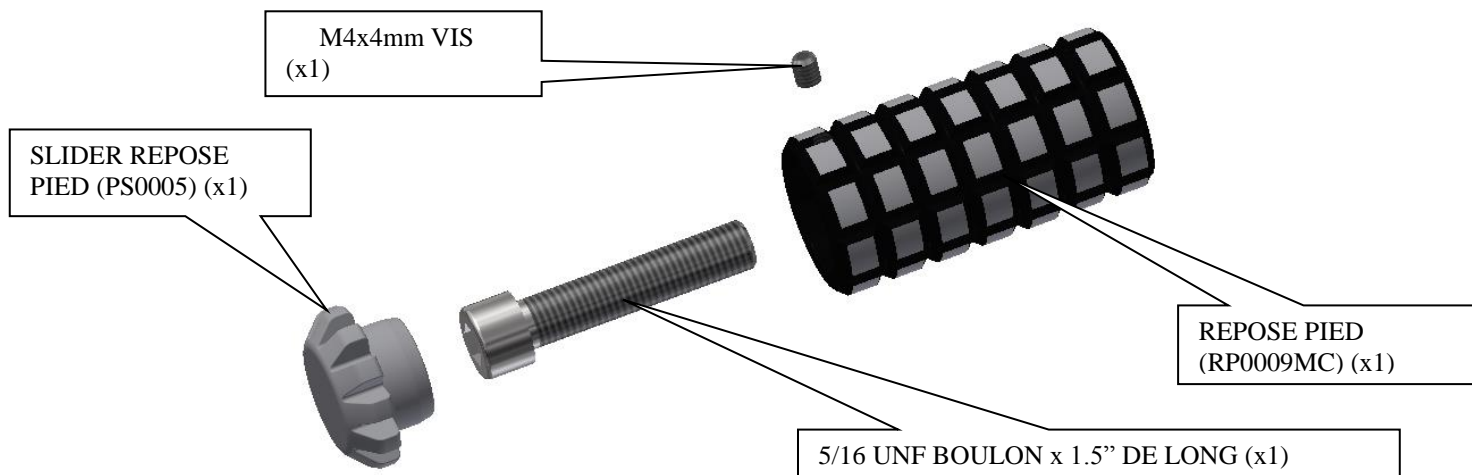

**OUTILS REQUIS**

- Clé Allen 1/4"
- 1/2" Clé Anglaise ou Clé à tube.



- Clé Allen 2mm.

### **NOTICE DE MONTAGE**

- Enlever l'écrou de blocage de la pointe de remplacement du coté du levier de vitesse puis enlever la pointe de pédale d'origine.
- Placer le boulon dans le repose pied de remplacement de façon à ce que la tête du boulon se place dans le contre alésage.
- Monter l'ensemble en position puis fixer à l'aide de l'écrou de blocage d'origine (Assurez-vous que le trou de fixation soit orienté vers le bas lors du serrage).
- Monter le slider de repose pied dans le contre alésage de façon à ce que le logo soit de niveau (il cache aussi la tête du boulon).
- Insérer la vis dans le trou fileté de la nouvelle pointe de pédale puis fixer le slider de repose pied en position.

ISSUE 1 26/10/2016 (NSY)

### **CONSUMER NOTICE**

The catalogue description and any exhibition of samples are only broad indications of the Products and R&G may make design changes which do not diminish their performance or visual appeal and supplying them in such state shall conform to the order. The Buyer acknowledges no representation or warranty (other than as to title) has been given or will apply to the Products other than those in R&G's order or confirmation and the Buyer confirms it has chosen the Products as being of merchantable quality and suitable for its particular purposes. Where R&G fits the Products or undertakes other services it shall exercise reasonable skill and care and rectify any fault free of charge unless the workmanship has been disturbed. The Buyer is responsible for ensuring that the warranty on the motorcycle is not affected by the fitting of the Products. On return of any defective Products R&G shall at its option either supply a replacement or refund the purchase money but shall not be liable if the Products have been modified or used or maintained otherwise than in accordance with R&G's or manufacturer's instructions and good engineering practice or if the defect arises from accident or neglect. Other than identified above and subject to R&G not limiting its liability for causing death and personal injury, it shall not be liable for indirect or consequential loss and otherwise its liability shall be limited to the amounts paid by the Buyer for the Products or the fitting or service concerned. These terms do not affect the Buyer's statutory rights.

### **R&G RACING RETURNS POLICY (NON-FAULTY GOODS)**

Returns must be pre-authorized (if not pre-authorized the return will be rejected). Goods may only be returned direct to us if they were purchased direct from us (customer must prove if necessary). Otherwise to be returned to original vendor. Goods must be in re-sellable condition, in the opinion of R&G Racing. All returns are subject to a 25% restocking and handling fee (25% of the gross value exc. P&P – at the prevailing price at time of purchase). The customer must pay any and all carriage charges. No returns of discontinued products, unless within 14 days of purchase. This policy does not affect your statutory rights and does not refer to faulty goods.

R&G Racing

Unit 1, Shelley's Lane, East Worldham, Alton, Hampshire, GU34 3AQ

Tel: +44 (0)1420 89007 Fax: +44 (0)1420 87301 [www.rg-racing.com](http://www.rg-racing.com) Email: [info@rg-racing.com](mailto:info@rg-racing.com)